

BRANIFF

WATER SOLUTIONS

ROAN ADA HET 1.28 GPF Toilet Rough in 12"

Bowl: TZ2039A020.B

Tank: TQ1042L020.B

Features

- High efficiency toilet 1.28 GPF
- Robust side-mounted tank lever
- 1000 MAP highest recognized in the industry
- Best in class 3" flush valve
- Pre-installed tank to bowl bolts
- Dual-fed siphon jet flushing system
- Rough-in tanks models: 10"/ 12" (standard) 14"
- Also available in round or elongated models
- Build on the Braniff Whistler platform
- Two piece toilet



Specifications

Configuration	2 Piece Elongated Front Toilet
Water consumption	1.28 gpf
Average weight	70 lbs
Average height	31 -1/4"
Water Surface	8 -1/8" x 7"
MaP Test	1,000 g
Rough - In	12"
Fully glazed trapway	2"

Certifications

- ASME A112.19.2-2018/CSA B45.1-18.
- EPA WaterSense High Efficiency Toilet



Warranty

- 10 years on Vitreous China
- 1 year on fittings

**Refer to the website for more details*

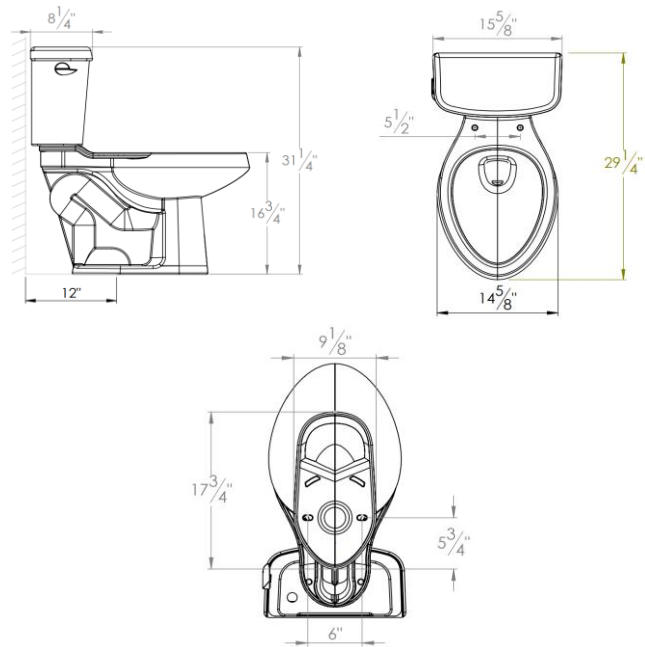

**Drawing image just as a reference to show Toilet's measurements*

Packaging details and other tank options

	Description	SKU	Weight (lb)	Length (in)	Width (in)	Height (in)	Pieces per pallet
Bowl	EL ADA	TZ2039A020.B	50	28-3/4"	16-1/8"	18-11/16"	18
Tank	RI 10" LH	TQ1041L020.B	24	17-1/8"	9-13/16"	16-3/4"	30
	RI 12" LH	TQ1042L020.B	26	16-3/4"	9-1/4"	16"	30
	RI 12" RH	TQ1042R020.B	26	16-3/4"	9-1/4"	16"	30
	RI 14" LH	TQ1043L020.B	31	16-1/8"	10-5/8"	16-1/8"	20

**The dimensions indicated are nominal and may vary within the tolerance range ±5% in dimensions less than 8" and ±3% in dimensions greater than 8"*



Customer Service Center:
 (855) 273-7001 (Toll Free)
 support@braniff.ws
 customerservice@braniff.ws

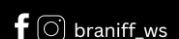

www.braniff.ws