

BRANIFF

WATER SOLUTIONS

ROAN EL HET 1.28 GPF Toilet Rough in 12"

Bowl: TZ2038A020.B

Tank: TQ1042L020.B

Features

- High efficiency toilet 1.28 GPF
- Robust side-mounted tank lever
- 1000 MAP highest recognized in the industry
- Best in class 3" flush valve
- Pre-installed tank to bowl bolts
- Dual-fed siphon jet flushing system
- Rough-in tanks models: 10"/ 12" (standard) 14"
- Also available in round or ADA models
- Build on the Braniff Whistler platform
- Two piece toilet



Specifications

Configuration	2 Piece Elongated Front Toilet
Water consumption	1.28 gpf
Average weight	67 lbs
Average height	29 -1/2"
Water Surface	7 - 3/4" x 6 - 3/4"
MaP Test	1,000 g
Rough - In	12"
Fully glazed trapway	2"

Certifications

- ASME A112.19.2-2018/CSA B45.1-18.
- EPA WaterSense High Efficiency Toilet

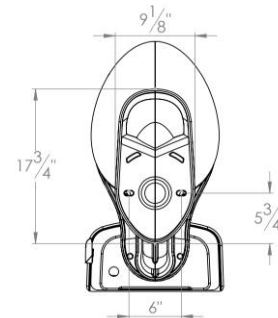
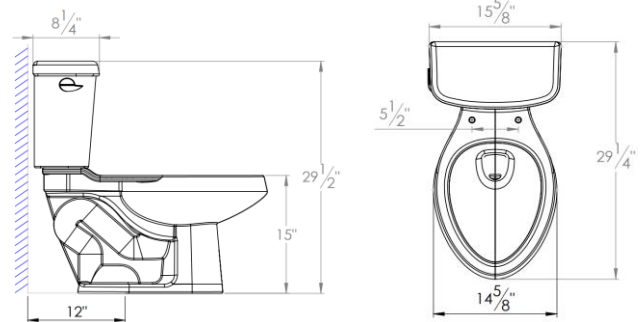

*Drawing image just as a reference to show Toilet's measurements

Warranty

- 10 years on Vitreous China
- 1 year on fittings

*Refer to the website for more details

Packaging details and other tank options

	Description	SKU	Weight (lb)	Length (in)	Width (in)	Height (in)	Pieces per pallet
Bowl	EL	TZ2038A020.B	47	28-15/16"	15-3/4"	17-1/8"	18
Tank	RI 10" LH	TQ1041L020.B	24	17-1/8"	9-13/16"	16-3/4"	30
	RI 12" LH	TQ1042L020.B	26	16-3/4"	9-1/4"	16"	30
	RI 12" RH	TQ1042R020.B	26	16-3/4"	9-1/4"	16"	30
	RI 14" LH	TQ1043L020.B	31	16-1/8"	10-5/8"	16-1/8"	20

*The dimensions indicated are nominal and may vary within the tolerance range $\pm 5\%$ in dimensions less than 8" and $\pm 3\%$ in dimensions greater than 8"



Customer Service Center:
(855) 273-7001 (Toll Free)
support@braniff.ws
customerservice@braniff.ws

