

Features

- High efficiency toilet 1.28 GPF
- Robust side-mounted tank lever
- 1000 MAP highest recognized in the industry
- Best in class 3" flush valve
- Pre-installed tank to bowl bolts
- Dual-fed siphon jet flushing system
- Rough-in tanks models: 10"/ 12" (standard) 14"
- Also available in elongated or ADA models
- Build on the Braniff Whistler platform
- Two piece toilet



Specifications

Configuration	2 Piece Round Front Toilet
Water consumption	1.28 gpf
Average weight	66 lbs
Average height	29 - 1/2"
Water Surface	8 - 1/4" x 7"
MaP Test	1,000 g
Rough - In	12"
Fully glazed trapway	2"

Certifications

- ASME A112.19.2-2018/CSA B45.1-18.
- EPA WaterSense High Efficiency Toilet



Warranty

- 10 years on Vitreous China
- 1 year on fittings

*Refer to the website for more details

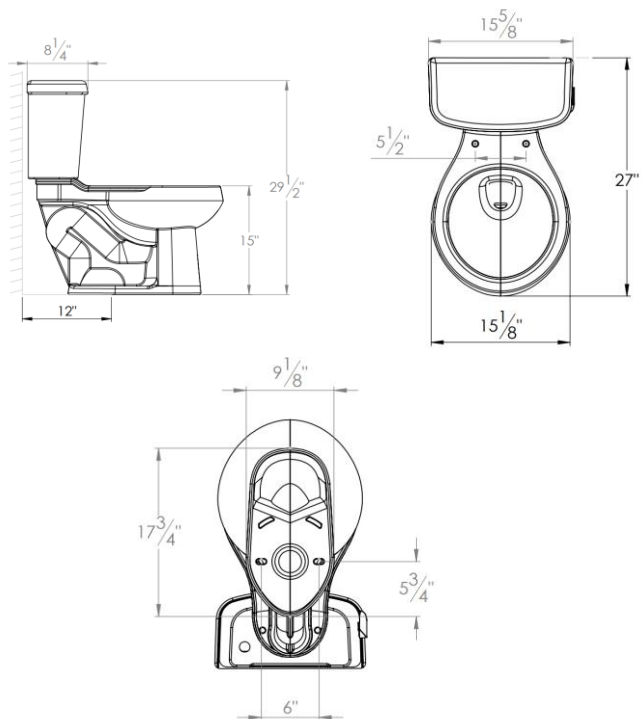

*Drawing image just as a reference to show Toilet's measurements

Packaging details and other tank options

	Description	SKU	Weight (lb)	Length (in)	Width (in)	Height (in)	Pieces per pallet
Bowl	RF	TZ2040A020.B	42	26-9/16"	16-1/8"	17-1/8"	18
Tank	RI 10" LH	TQ1041L020.B	24	17-1/8"	9-13/16"	16-3/4"	30
	RI 12" LH	TQ1042L020.B	26	16-3/4"	9-1/4"	16"	30
	RI 12" RH	TQ1042R020.B	26	16-3/4"	9-1/4"	16"	30
	RI 14" LH	TQ1043L020.B	31	16-1/8"	10-5/8"	16-1/8"	20

*The dimensions indicated are nominal and may vary within the tolerance range ±5% in dimensions less than 8" and ±3% in dimensions greater than 8"

