





BRANIFF®

NEW
ROAN TOILET



NO CALLS QUALITY!
Made in North America

-  (832) 327-7418
-  customerservice@braniff.ws
-  www.braniff.ws
-  @braniff_ws

Features

- High efficiency toilet 1.28 GPF
- Robust side-mounted tank lever
- Best in class 3" flush valve
- 1000 MAP, Recognized as best in industry
- Pre-installed tank to bowl bolts
- Dual-fed siphon jet flushing system
- Rough-in tanks models: 10"/ 12" (standard) 14"
- Also available in round or ADA models
- Built on the Braniff Whistler platform
- Two piece toilet



Specifications

Configuration	2 Piece Elongated Front Toilet
Water consumption	1.28 gpf
Average weight	67 lbs
Average height	29-1/2"
Water Surface	7-3/4" x 6-3/4"
MaP Test	1,000 g
Rough - In	12"
Fully glazed trapway	2"

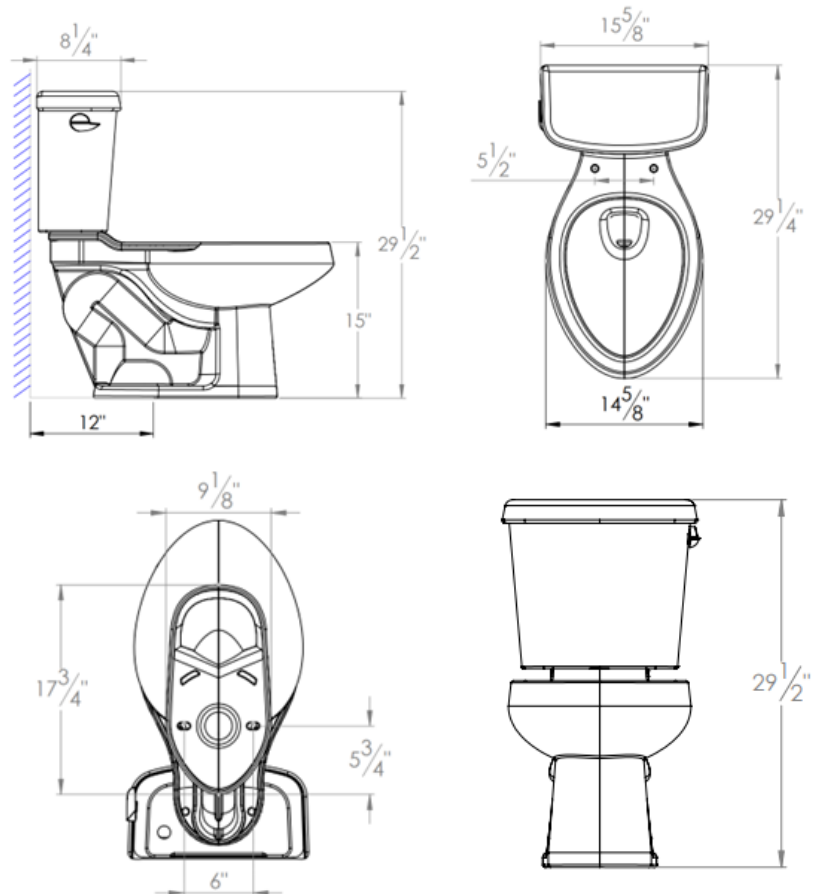

Certifications

- ASME A112.19.2-2018/CSA B45.1-18.
- EPA WaterSense High Efficiency Toilet



Warranty

- 10 years on Vitreous China
- 1 year on fittings

*Drawing image just as a reference to show Toilet's measurements